

Solution Brief

mSFA: Mobile Sales Force Automation Advantage

ADD MOBILE FORCE TO YOUR SALES FORCE



EMPOWERING YOUR FIELD FORCE WITH ANYWHERE, ANYTIME ACCESS TO SAP ERP.

In today's highly competitive world, your sales team needs to be empowered with tools and technology that allows them to access your SAP ERP and serve the customers on demand when they meet them. It has become imperative to improve the efficiency of the sales force by providing them with access to quality data from backend systems for a 360 degree view of the customer. This access to data in the field provides a single-point of resolution for customer queries, thus being able to respond efficiently and effectively to customer demands. It also empowers your sales team to spend quality time talking to your prospects and customers rather than sitting in office and entering data into a complex system with multiple screens.

mSFA (Mobile Sales Force Automation) is a SAP NetWeaver Mobile 7.1 based solution that empowers the field sales force with on-demand access to your SAP ERP system. The power of mobility provides more time to sell, thereby enhancing your sales team productivity. mSFA is capable of handling complete Sales Order processing, provides instant access to ATP inventory, customer account information, available credit and shipping details etc. The application runs on all mobile phones based on Symbian S60 platform and also on Blackberry and Windows based mobile devices.

Available to Promise Inventory

Near Real time ATP Inventory check ensures that goods can be allocated to meet customer demand and commitments with virtual certainty of fulfillment according to plan.

Sales Order Management

Mobile order entry speeds up the ordering process and removes duplicate data entry by back-office, resulting in efficient and error free ordering process. The data entry errors are minimized by use of sales person specific context helps on mobile device.

Order Status and Confirmation

Order status on mobile ensures that Sales Force get more time to sell.

Manage Deliveries

Managing deliveries on the go, accelerates the sales process ensuring faster deliveries reducing communication delays and inventory cost.

Payment Collection

Near real-time customer billing, payments, and collection status information results in faster payments.

ROUTE PLAN & DAILY TASKS

Application supports route planning and can push daily schedule from SAP ERP to the salesperson's handset.

ACCOUNT & CONTACT MANAGEMENT

Save time and money by getting a complete view of customer account information, thus maximizing your sales effectiveness.

OFFLINE AND NEAR ONLINE SUPPORT

Application supports offline data entry and on-demand sync which allows end users to be in full control of transactions at times.

BUSINESS ISSUES

- Unprepared sales representatives calling customers, prospects, or partners with limited insight into an account's history, account, decision-makers, timelines, etc.
- Poor customer data quality, such as wrong contact person information, inaccurate order information etc .
- Non documented sales activities, such as visit reports, resulting in inaccurate resource planning, incomplete account handover, etc.
- Need to connect to corporate network and transact with SAP ERP at the end of the day.
- Limited number of Enterprise Applications support S60 mobile phones(Nokia, Samsung, Sony Ericsson etc).

SOLUTION

- Real-Time information on mobile devices enables Sales representatives to be better prepared for customer meetings and calls. This leads to improved response times to customers, thereby resulting in shorter sale cycles and higher customer satisfaction.
- High quality data: Ability to update information online in the field leads to better data quality, reduced data entry errors and work duplication.
- Multi device support: Supported on Symbian S60 platform, Blackberry and Windows mobile devices.

Solution Architecture

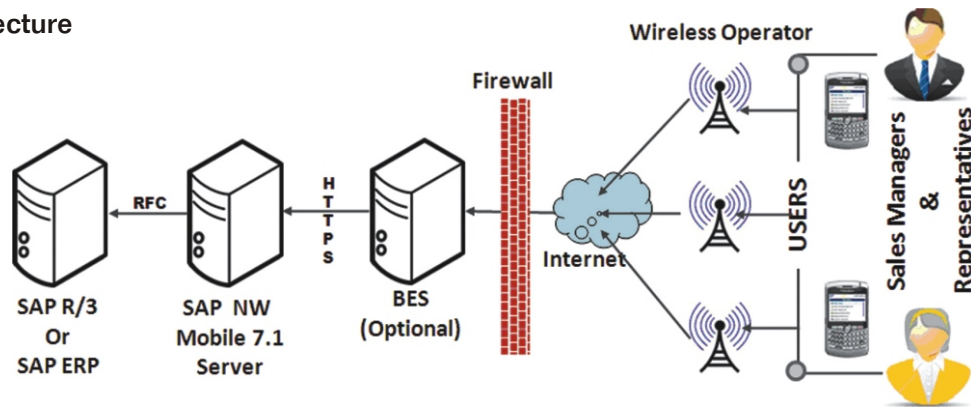

QUICK FACTS

Summary

mSFAs is a SAP Netweaver Mobile 7.1 based sales force automation tool for SAP ERP. It empowers your field to be connected with your SAP ERP, whenever they want, wherever they go. The application is supported on the popular Symbian S60 devices like Motorola, Nokia, Sony Ericsson, LG, Samsung, etc. and smart phones from Blackberry and Windows Mobile.

Business Challenges

- Lack of real-time access to SAP ERP while on the field
- Cannot update customers on orders, shipments, inventory, pricing.
- No real-time customer overview on payments and invoices
- Sales activities need to be updated at end of day by connecting to corporate network.
- Limited number of Enterprise Applications support Symbian S60 mobile phones(Nokia, Samsung, Sony Ericsson etc)

Solution Features

- Order tracking and approval
- Delivery status
- Inventory
- Payment collection
- Account Management
- Contact Management
- Route Planning
- Reports
- Dashboard

Solution Implementation

- End to end Sales Cycle Implementation
- Easy to deploy (Rapid Go-Live) in 6-8 weeks
- Easy to enhance and add functionalitie
- Can be extended to all Mobile Device platforms

Key Business Benefits

- Better Decision-Making: Empower your sales force with instant access to complete, relevant, and up-to-date information
- **Increased Productivity:** Provide field employees with relevant information and insight
- Responding quickly to sales opportunities and payment collections.
- **Enhanced Customer Satisfaction:** Respond to customer queries on the spot, hence shorten sales cycle.
- **Empowered Field Resources:** Enable seamless real time data flow between mobile employees and the central office
- Accurate Updates: Increase visibility into field sales activities

For more information on mSFA: Mobile Sales Force Automation Advantage, please visit <http://www.arteriatech.com> | mail sales@arteriatech.com | call +91 80 4242 3800